

Applications

Lifting and handling of *big-bag*.

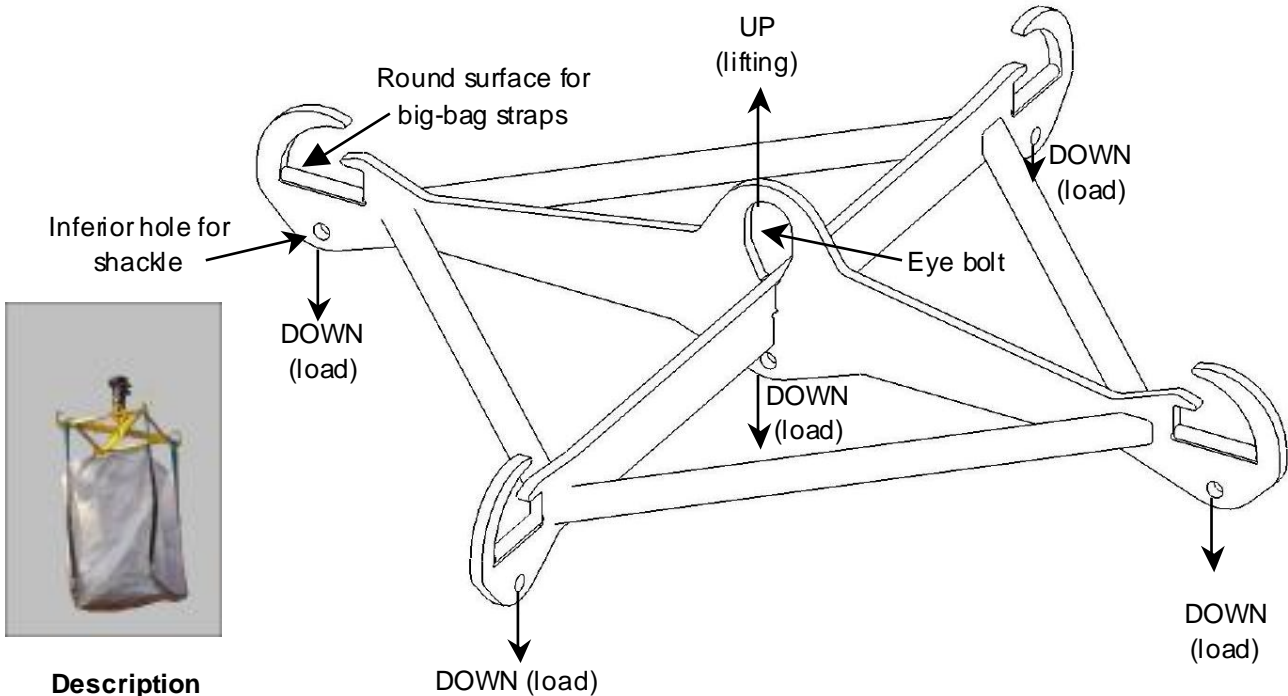

Description

Range of fixed X shaped lifting beams equipped with 4 bearing surfaces for the lifting of soft containers, like **big-bag with 4 lifting points set up cornerwise or diagonally** (if in doubt, please ask the supplier).

Five lower holes allow shackles or hooks to be attached the XBAG beam, for occasional lifting operations. These lower holes have the following capacity:

- Total WLL of the big-bag to the central point,
- WLL of the XBAG distributed on the 4 peripheral points.

Functioning (method to use excluding all other alternatives):

Before the two lifting examples given below: attach the beam by its central ring to lifting equipment, with an adequate load capacity and equipped with a securing device (such as a safety hook).

1. Lifting of a soft container, like big-bag: position the lifting beam vertically to the soft container. Hang up the 4 straps to the lifting beam angles, then lift vertically, while making sure of the balance.
2. Occasional lifting of other load: attach the shackles and/or other devices to the lower points. Position the lifting beam vertically to the load. Attach the load and then lift vertically. After use, systematically remove the shackles and/or hooks, which may be attached to the beam, so that the beam will be ready to be used again for big-bag lifting.

Reminder: these two lifting cases are incompatible and can not be used at the same time.

General characteristics

- Manufactured without load bearing welds.
- Hot epoxy coating.
- Safety factor: 3 in accordance with the EN 13155.2003 nom.
- Product conforms to the French regulation, in particular the decree of 01/03/2004 relating to the check on lifting devices and the European Directive n°98/37.
- Product with EC marking and delivered with a declaration of conformity and instructions for use.

Important instructions

- **NEVER USE FOR PERSONNEL LIFTING.**
- Strictly forbidden to either be under or walk under the load.
- It is imperative to respect the value of the working load limit (WLL).
- Hang up the lifting beam only by its central ring. The lifting beam must always be used horizontally, with the ring in upper position (cf. diagram previous page). Any other position is prohibited.
- Make sure to position the 4 straps of the big-bag on the rounded bearing surfaces. The other parts of the lifting beam are not appropriated. These bearing surfaces are strictly reserved for the straps hanging.
- During the big-bag lifting, make sure the 4 straps do not move. It is advised to stop the lifting as soon as the straps are in a constrained position, in order to visually check the 4 hanging points.
- The straps of the big-bag must not be twisted during the lifting.
- In case of lifting with 2 diagonal points, the XBAG lifting beam WLL is 50% reduced.
- Balance the load in order to keep it horizontal during the lifting. Try beforehand lifting.
- Check the WLL and the load distribution when lifting by means of one or more holes for shackles (see dimensional characteristics).
- Never use the lifting beam without visually priory checking the big-bag and its straps.
- Working temperature: -20° to +100°C.

Dimensional characteristics

Reference	Group code	WLL* (kg)	Big-bag width		Plate thickness	Total height	C	D	Weight empty (kg)
			mini	maxi					
XBAG1.5	54628	1500	880	990	12	242	78	32	27
XBAG2.5	54638	2500	880	990	15	242	75	29	34

Dimensions in mm, except opposite indication

*** Capacity by using the 4 lifting points or the central point of the lifting beam. This WLL value is 50% reduced in case of lifting with 2 diagonal points.**

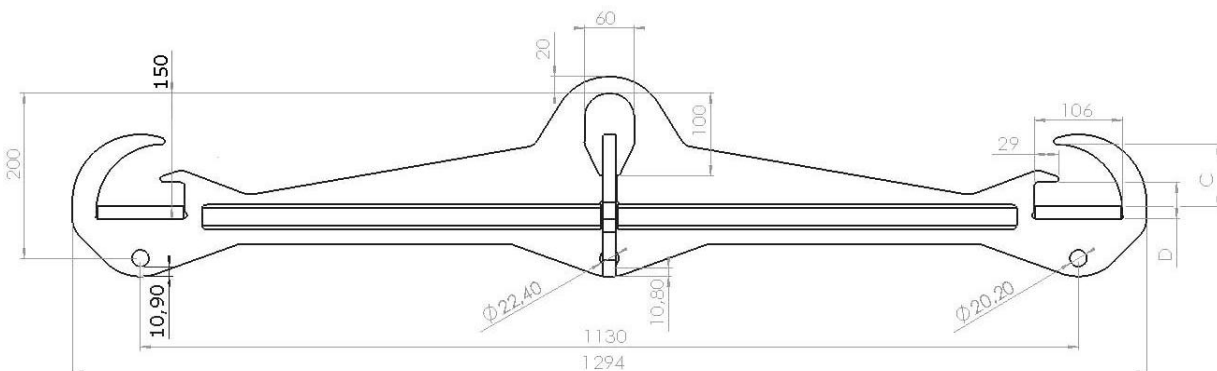

Nota: references in the **Charlet** range of the shackles compatible with XBAG lifting beams.

Reference	Lower central point's WLL (kg)	Ref. shackle	Unit weight (kg)	Lower peripheral point's WLL (kg)	Ref. shackle	Unit weight (kg)
XBAG1.5	1500	C033M	0.9	375	C033M	0,9
XBAG2.5	2500	C040H	1.2	625	C033M	0,9